







# Kmuun D1 Pro

Intelligent entry system  
user manual

v 0.0.4

<b>Indoor unit</b>  Width:232 Height:155 Thickness:24	<b>Indoor unit installation plate</b>  Width: 182.6 Height: 103.8 Thickness: 3.5	<b>Outdoor Ebeller</b>  Width: 68 Height: 204 Thickness: 24	<b>Outdoor Eguarder</b>  Width: 68 Height: 204 Thickness: 24	<b>Outdoor unit installation plate</b>  Width: 136 Height: 204 Thickness: 3.5 (mm)	<b>latch removal</b> 
--	---	--	---	---	---

<b>Material &amp; Finish</b> Anodized Aluminum Alloy Tempered Glass ABS	<b>Keyboard</b> 6 to 8-passcode 20-digit pseudo passcode Zone Smart Backlighting RFID Card Induction	<b>Facial recognition</b> Distance: 30 - 120 cm Height: 1 - 2.2 m FRR: < 0.01% FRR: < 0.00001% Speed: < 350 ms	<b>Power</b> 24 V DC  <b>Operating Environment:</b> RH(Non-cond): 20 % ~ 93 % Temp: -10 °C ~ 55 °C	<b>APP</b> Balter ERA IP 	<b>In The Box</b> <ul style="list-style-type: none"> <li>Indoor Unit</li> <li>Outdoor Unit</li> <li>Accessories</li> <li>RFID Cards</li> <li>Pin &amp; User Manual</li> </ul>
<b>Installation</b> Remote wall Install perfect Modular design	<b>Fingerprint</b> Resolution:500DPI FRR:≤0.15% FAR:≤0.00004% Auto-update	<b>Peephole</b> Night Vision with LED Fill Light Wide-Angle Camera 1280 x 720 Resolution	<b>Voice Guidance</b> Chinese English	<b>Video intercom</b> Remote unlock Alerts Access Sharing	<b>Firmware</b> D1P-0230-001 For Testing Purposes Only
<b>Storage</b> 100 keys					

Installation Diagram (Horizontal Version)

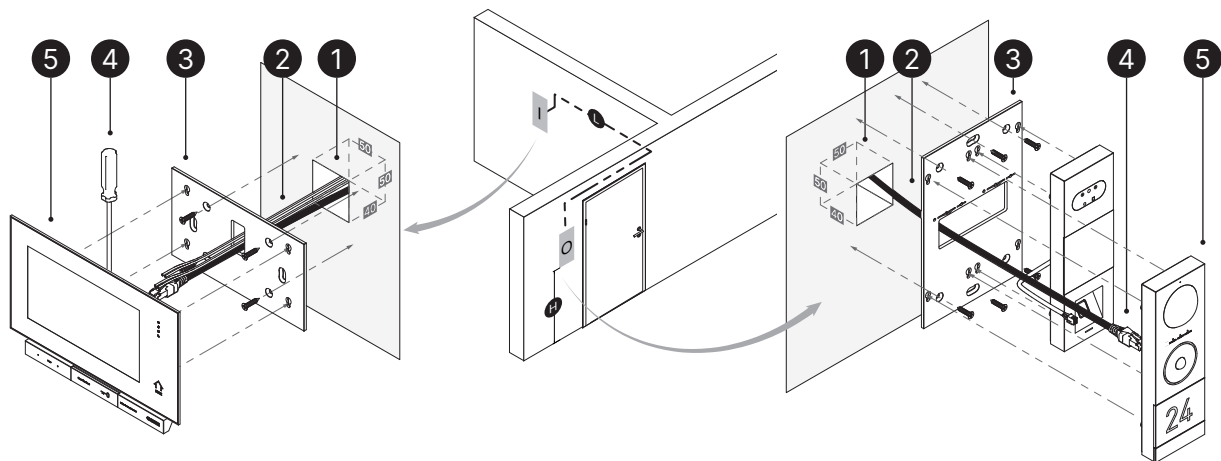

- After determining the indoor and outdoor unit locations, cut a 50×50×40mm wall groove and pre-install the conduit for future use.
- Ensure proper operation by meeting the following:  
Line length L: <100 m    Height H: 1.35-1.45 m
- Thread cables through conduit (shown below)
- Unit Connection Cable \*    CAT 6a STP cable
- 24V DC Power Cable    RVV2 x 2.0 mm<sup>2</sup> 双芯线
- Lock Control Cable    RVV2 x 2.0 mm<sup>2</sup> 双芯线
- \* - Terminate the cable with a Cat 6A RJ45 connector per national standards.
- Secure both mounting brackets to the wall using M4 x 40 self-tapping screws, aligning cable ports with the pre-cut groove.
- Connect pre-run cables (power, control, Connection-unit) to indoor and outdoor video units, then link the video unit to the access control unit.
- Install units to plate: indoor unit, outdoor Ebeller/Eguarder
- Remove outdoor unit by inserting the release pin into the right-side slot and pushing upward. For horizontal units, disassemble from right to left; for vertical units, from top to bottom.

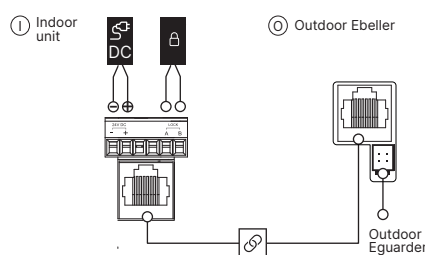

!! Connect all wiring without power. Follow diagrams precisely. After installation, power on. If malfunction occurs, power off and recheck connections. If issues persist, contact technical support.

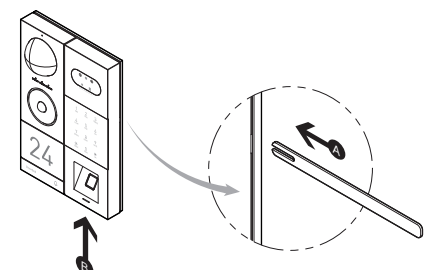

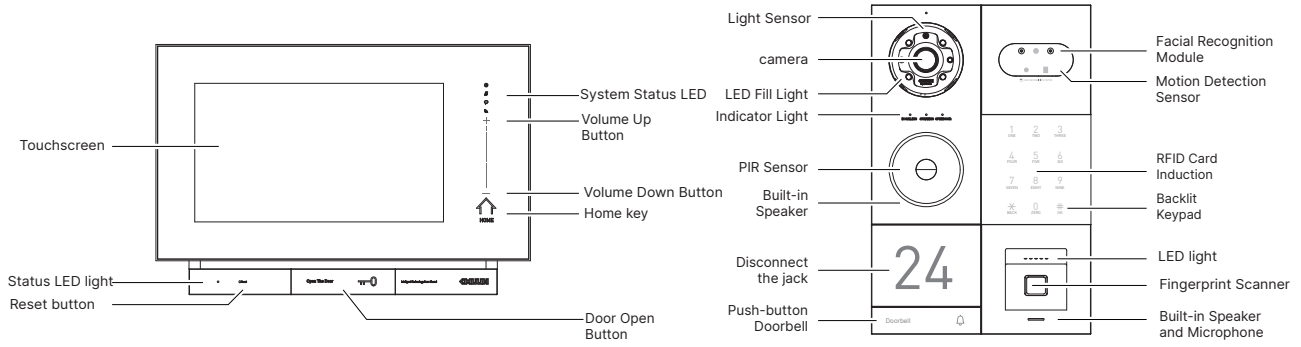

Outdoor Eguarder Setup Process

To start, briefly press the "reset" button on the indoor unit using a pin, or press \* + # on the outdoor keypad. In factory mode, the voice-guided menu opens directly. Otherwise, admin verification is needed. The voice lists 6 options, but only 4 can be configured locally on this device.

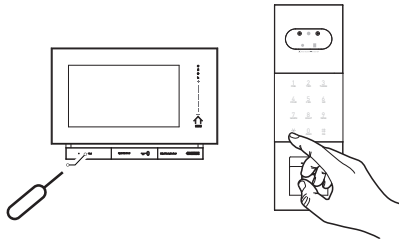

1 Add User 2 Delete user 3 system setting 6 Factory Reset

1 Add User

- 🔊 Operation success, User 00.  
In initial setup mode (factory mode), the system will enter administrator configuration. You can register up to 10 administrator keys.
- 🔊 Enter user ID.  
After the voice prompt, enter a new or existing user ID (00-99), then press # to confirm. 00 = administrator | 01-99 = standard user.

user ## enter access key 1 Sign up fingerprint, passcode, RFID Card.

2 Sign up facial recognition

1 Sign up fingerprint, passcode, RFID card.

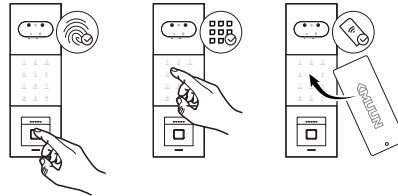

**Fingerprint Enrollment:** Place the finger on the external fingerprint sensor. Follow the voice prompt "Please press again" and repeat several times until "operation successful" is announced. Interruption or incorrect presses may cause failure.

**Passcode Setup:** Enter a 6-10 digit Passcode on the keypad. Re-enter it as prompted. If "operation success" is heard, the passcode is set. Passcodes with invalid length or mismatched entries will be rejected. Repeated passcodes are not allowed.

**Access Card Registration:** Hold the card close to the keypad area. A voice prompt "operation success" confirms registration. Duplicate cards will be rejected.

2 Sign up facial recognition

👁️ : Look directly at the camera

**Face Registration:** Look directly at the camera and follow the voice instructions. "Operation successful" confirms registration.

Duplicate faces will be prompted. Process times out if delayed. Optimal range: 50 cm.

2 Delete user

- 🔊 Enter user ID  
After the voice prompt, enter a configured user ID (01-99) and press #. If "Operation successful" is announced, the user is deleted. Incorrect IDs will result in failure. User 00 (administrator) cannot be deleted.

3 System Setting

- 🔊 1 Time Setting 2 set volume 3 Verification Mode 4 set language  
Select a menu to configure after the voice prompt.

1 Time Setting

Follow voice prompts to enter the date (YYMMDD) and time (HHMM). Incorrect settings may disable temporary passcode function.

2 Volume Settings

- 🔊 1 Volume Up 2 Volume Down

3 Verification Settings

- 🔊 Dual Verification | Single Verification  
Follow the voice prompt to select a method. Single verification requires one credential. Dual verification requires two different credentials.

4 Language Settings

- 🔊 1 Chinese 2 English

6 Factory Reset

- 🔊 Initializing... Initialization successful.  
Press # to confirm. After the voice prompt, initialization is complete. The device will enter factory mode. Configure new credentials promptly.

Auxiliary Functions

Factory Reset

Hold the reset button with a pin for 6s until "Initializing ... Success" is heard. Release and wait. Unlock will require no credentials. Reconfigure immediately.

Lockout Mode

Triggered after 5 failed attempts. The external unit locks and announces "System locked. Try again later." Automatically resumes after 3 minutes.

Indoor Unit Basics



Doorbell Call

When the outdoor button is pressed, the indoor screen shows the caller. Button 1: Take photo. Button 2: Record video. Button 3: Unlock door. Button 4: Talk intercom. Button 5: Return home

**Warm Reminder:** The D1 PRO device does not support connection via Android APP

Notes

- Before use, read all instructions. Damages from non-compliance are not covered by the warranty.
- Use only manufacturer-specified accessories.
- Avoid forcefully disassembling to prevent damage.
- Keep away from water or splashing environments.
- Do not clean the fingerprint sensor with sharp objects or corrosive liquids.
- Maintain cleanliness to prevent surface damage.
- Clean with a soft cloth and water.
- Set up the device immediately after installation.
- Keep the admin password confidential.
- If the RFID card is lost, reset the device and set up new keys.

Warranty

- This product's after-sales service strictly follows the "Consumer Protection Law of the People's Republic of China" and the "Product Quality Law of the People's Republic of China," with the following after-sales service terms:
  - Within one year from the day after you receive the product, if any performance failure listed in the "Product Performance Fault List" occurs, the product will be repaired free of charge based on the warranty type after being inspected and confirmed by the KMUUN Service Center.
  - For damages not covered by the warranty or caused by human factors, the KMUUN Service Center can still provide repair support, but a repair fee will be charged according to the actual condition of the product.